



# QUANTASEP® Trusty 100

## Sanitary Bench Top Scale-Up System

QuantaSep® Trusty 100 is a fully integrated system to enable methods development, validation studies, scale-up/ scale-down studies and troubleshooting on a bench scale. With its powerful and easy to use Windows® based software, it allows the user to automatically equilibrate load, wash, elute and regenerate up to three columns. The user can also control each step in the purification based on UV, pH, conductivity, time, temperature, air sensors or any external user-defined variable. As the sensors monitor column outflow, the computer reads the information to automatically change buffers, start gradients and collect fractions, stepping through the method as you programmed it. The computer logs all data for analysis and printout.



Flow Range 1-100 ml/min

## 8 Mission Critical Ways a QuantaSep® Trusty 100 Can Help Get Your Department In Control

- ✓ Reduce Project Backlog
- ✓ Improve Product Quality and Reliability
- ✓ Reduce Batch Failures
- ✓ Unattended 24/7 Runs
- ✓ Reduce Tedious Report Writing
- ✓ Easy Scale-Up/Scale-Down Studies
- ✓ Save Time
- ✓ Space Efficient

## QuantaSep® Trusty100 Highlights

- Automates buffer delivery, column switching, fraction collection, based on UV, pH and conductivity.
- Small footprint can fit on bench-top, laminar flow hood or cold room.
- Large dynamic flow range – 1-100 ml/min
- Graphical, intuitive software “dashboard” for easy operation and training.
- Automated GMP reports
  - Complete batch reports
  - Event and logs
  - Chromatograms and calibration history
- Precision Hardware
  - 100:1 turndown ration for accurate gradients
  - Low system volume
  - Integrated pH, UV, condition flow cell
- Safety features
  - Active air trap minimizes “bubble trap dilution”
  - Leak and pressure alarms
  - Built in safety interlocks
  - Software method checks
  - Software security prevents unauthorized operation and tampering

## The Right Combination of Simplicity and Power

The simplicity of QuantaSep®'s interactive graphical user interface gives the system its efficiency and power by making it easy to learn and use. You don't need to refer to printed flow diagrams and manuals. Because, even if you have little or no computer experience, QuantaSep®'s intuitive on-screen operations make the system easy to use-from the moment you plug it in.

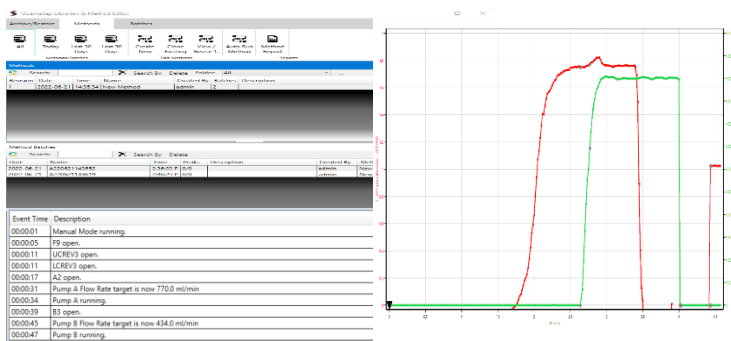

## QuantaSep® Trusty Has What It Takes

The QuantaSep® Trusty System can automate many of the routine manual tasks related to process development and free up key scientists' time to handle additional mission-critical projects. It allows the process development departments to manage the deadlines to produce clinical/pre-clinical material, scale-up processes and trouble-shoot or downscale production problems all within existing headcount and budgetary constraints. The payback for these systems has ranged from 3-18 months!

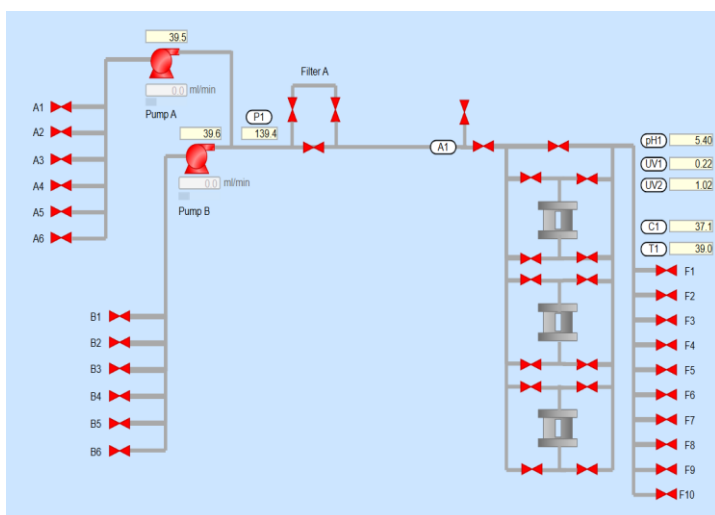

33470 WESTERN AVE, UNION CITY, CA 94587  
 PHONE: 510-475-0650 FAX: 510-440-5395  
 HTTP://WWW.SEPRAGEN.COM

## QuantaSep® Trusty100 Specifications

- 12 user selectable buffers
- 3 user selectable columns forward/reverse/bypass mode
- 10 user selectable fractions with fraction collect capability
- Sanitary design
- Range: 1-100 ml/min,  $\pm 3\%$
- Hold up volume: 7 ml
- Small component footprint: 20" x 24" x 25"
- 5%-95% gradient capability
- Pressure rating: 100 psi
- Tubing: 1/16" I.D.

## Wetted Materials of Construction

Silicone, polyethylene and polypropylene tubing; polypropylene valves and fittings; PTFE diaphragms; glass/quartz/316L stainless steel sensor components.

## Components Specifications

280 nm UV 0-2 Au  
 254 nm UV 0-2 Au (Optional)  
 Conductivity Sensor 0-200 ms,  $\pm 5\%$  pH  
 Sensor 1-14 pH,  $\pm 0.2$   
 Air Bubble > 0.20"  
 Pressure Sensor 0-100 psi  $\pm 1$  psi  
 Leak Sensor 5 ml leak volume

## Warranty, Installation & Support

All QuantaSep®'s are backed by Sepragen's one year limited warranty. Installation and training, along with IQ/OQ are performed by Sepragen Service Group. Preventative maintenance and Total maintenance service is provided at added cost. Validation support packages are also available.

To learn more call:  
**(510) 475-0650**

E-mail: [info@sepragen.com](mailto:info@sepragen.com)